

Company name: \_\_\_\_\_  
 Buyer's name: \_\_\_\_\_ Phone number: \_\_\_\_\_  
 Qty needed: \_\_\_\_\_ Delivery: \_\_\_\_\_

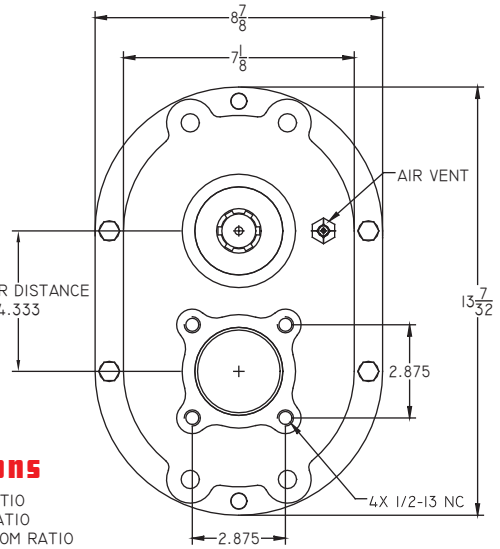

**Options**

- 1:1 RATIO
- 2:1 RATIO
- CUSTOM RATIO
- NO OIL
- OIL FILLED
- NOT PAINTED
- PAINTED

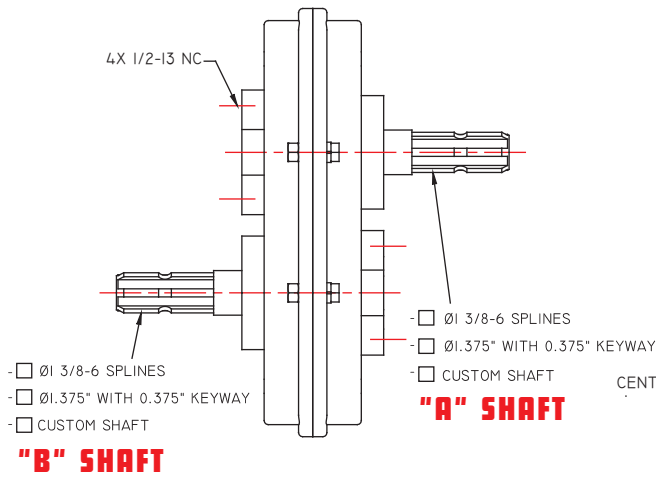
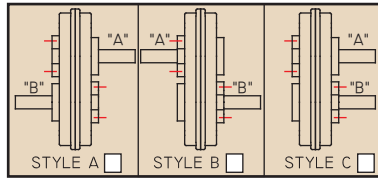
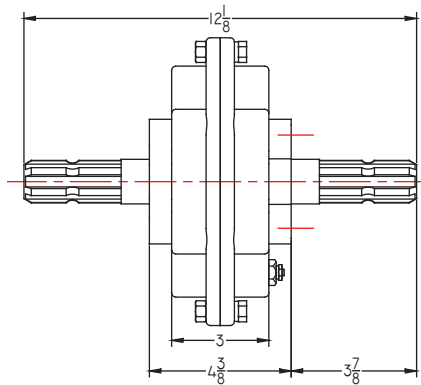

SPECIFY IF "A" IS THE  PINION OR THE  GEAR

RATIO		INPUT RPM				
		500	1000	1500	2500	3500
<input type="checkbox"/> 1:1	INPUT HP	19	36	51	80	107
	INPUT TORQUE IN.LB	2394	2268	2142	2016	1926
<input type="checkbox"/> 2:1	INPUT HP	10	18	26	41	55
	INPUT TORQUE IN.LB	1260	1134	1092	1033	990

MOUNTING POSITION FOR OIL LEVEL PLUG, AIR VENT AND DRAIN PLUG

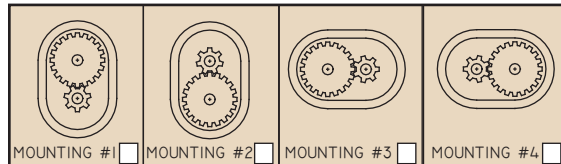

DRAWING ABOVE SHOWS A-I (STYLE-MOUNTING)

PLEASE SEND A DRAWING IF CUSTOM SHAFT DESIGN IS NEEDED

GEARBOX WEIGHT: 50 POUNDS